

TECHNICAL DATA SHEET

QUAKE

MSE-118 SUBWOOFER



The MSE-118 Quake is a powerful horn-loaded subwoofer – the ultimate no-compromise solution for both touring applications and high-SPL installations – matching the utmost in drive unit performance with tireless research into the development of horn technology.

The result is one of the finest subwoofers on the market today. The magnitude and phase response produced by the combination of the 9' (2743mm) horn and awesome 5" voice coil, 18" drive unit allow Quakes to be easily matched to any mid/high enclosure to create powerful, effortless low frequency reproduction.

Quake was designed to be used in multiples, with four or more being the ideal number to complete the horn mouth – which in turn not only increases overall system efficiency and lowers the low frequency cut-off, but also gives low frequency pattern control, keeping the energy in front of the system instead of behind it. This is achieved without the use of additional amplifier channels or system processing.

The rugged enclosure is constructed from CNC-machined Finnish multi-laminate Birch plywood, rebated, screwed & glued together for maximum strength. The enclosure is finished in black semi-matt textured paint, however other colours are available on request. Quake is supplied as standard with steel bar handle and heavy-duty castors, and has interlocking nylon feet for stability when stacked. A foam-backed hex punched steel grille protects the drive unit from damage and moisture. Quake represents an ideal solution for any system where high power, effortless low frequency reproduction is required, regardless of the application or style of music being reproduced.

Quake can also be fitted with the optional DA-1 amplifier module for added flexibility.

TECHNICAL SPECIFICATIONS

ENCLOSURE TYPE:	exponential/hyperbolic folded horn
DIMENSIONS (HxWxD):	1200 (47.2) x 574 (22.6) x 950 (37.4) mm/(ins)
NET/SHIPPING WEIGHT:	109/116kg
FREQUENCY RESPONSE ¹ :	35Hz – 200Hz +/- 3dB (single enclosure) 27Hz – 200Hz +/- 3dB (four enclosure stack)
SENSITIVITY ² :	106dB (1W/1m) (single enclosure) 110dB (1W/1m) (four enclosure stack)
DISPERSION ³ :	Omnidirectional
DRIVE UNITS:	1 x 18" (457mm) LF cone drive unit
POWER HANDLING:	800W RMS, 1600W program
MAXIMUM SPL:	134dB continuous, 140dB peak
NOMINAL IMPEDANCE:	8 ohms
CROSSOVER:	Active, recommended below 150Hz (24dB/Octave L-R)
CONNECTORS:	2 x Neutrik Speakon™ NL4MPR
ENCLOSURE:	18mm (3/4") multi-laminate Birch plywood – rebated, screwed & glued. Finished in black Warnex textured paint
GRILLE:	Foam backed hex-punched steel
OPTIONS:	Colours Touring Wheelboard Connectors DA-1 Amplifier Module

Notes on measurement conditions:

¹Measured on-axis

²Average SPL over stated bandwidth with 1W input, measured at 1m

³Nominal dispersion, averaged over stated bandwidth

EM Acoustics operates a continuous policy of research and development, and as such reserves the right to alter specifications without notice



TECHNICAL DATA SHEET

QUAKE

MSE-118 SUBWOOFER



ENGINEERING DRAWING

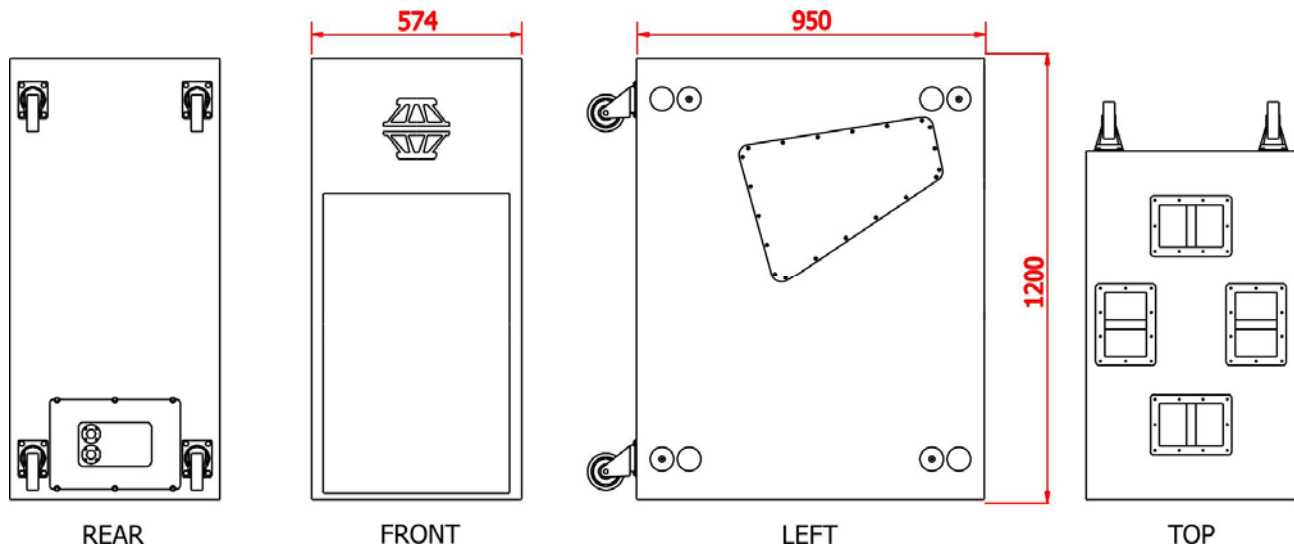

FREQUENCY/PHASE RESPONSE *(four enclosure stack, 1W total input)*

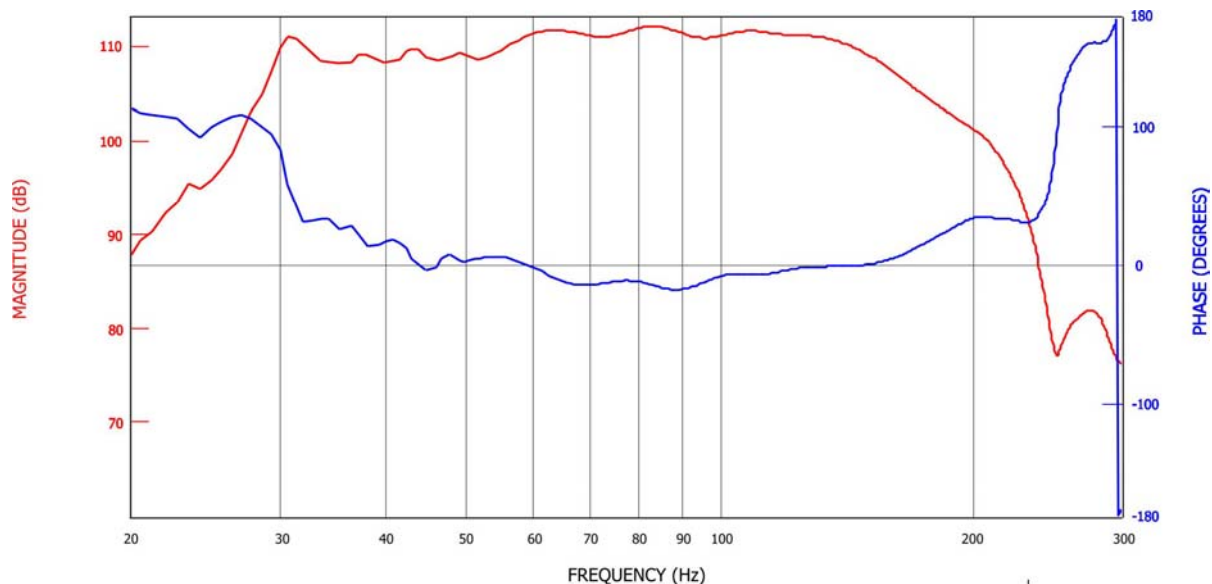

ENCLOSURE OPTIONS

Colours

Supplied as standard in black, however white & grey are available as options. By special order, any colour can be provided if the relevant RAL or Pantone colour code or a colour sample is provided.

Connectors

Neutrik Speakon™ NL4MPR connectors supplied as standard. MSE-118 can be supplied with XLR connectors, or non-standard connectors by special order.

Touring Skids

Polymer skids can be fitted to the sides of the enclosure, to protect the paint finish as well as facilitate interlocking of enclosures when in normal stacking configuration.

